

Bioengineering 280A
Principles of Biomedical Imaging

Fall Quarter 2006
X-Rays Lecture 3

TT Liu, BE280A, UCSD Fall 2006

Topics

- Address questions from last lecture
- Review image equation
- Linearity
- Delta Functions
- Superposition
- Convolution

TT Liu, BE280A, UCSD Fall 2006

X-Ray Spectrum

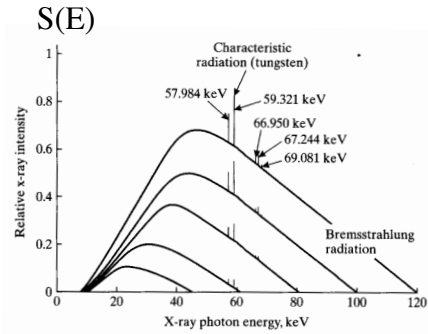
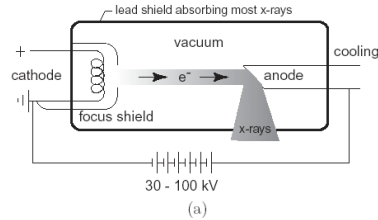

$$\phi = \int_0^{\infty} S(E') dE'$$

$$I = \int_0^{\infty} S(E') E' dE'$$

TT Liu, BE280A, UCSD Fall 2006

Prince and Links 2005

Magnification of Object

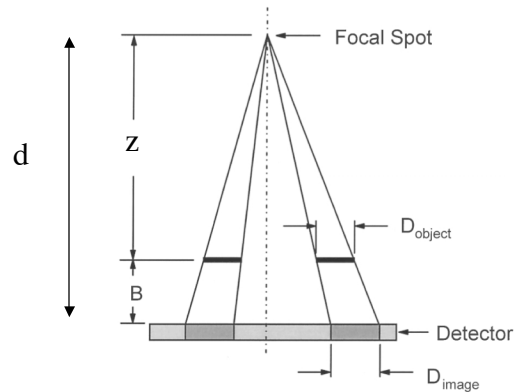

$$M(z) = \frac{d}{z} = \frac{\text{Source to Image Distance (SID)}}{\text{Source to Object Distance (SOD)}}$$

TT Liu, BE280A, UCSD Fall 2006

Bushberg et al 2001

Magnification of Object

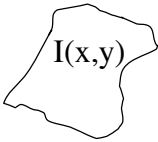
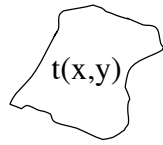

$$M = 1: I(x,y) = t(x,y)$$

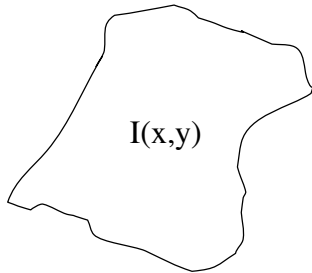

$$M = 2: I(x,y) = t(x/2, y/2)$$

$$\text{In general, } I(x,y) = t(x/M(z), y/M(z))$$

TT Liu, BE280A, UCSD Fall 2006

Bushberg et al 2001

Source magnification

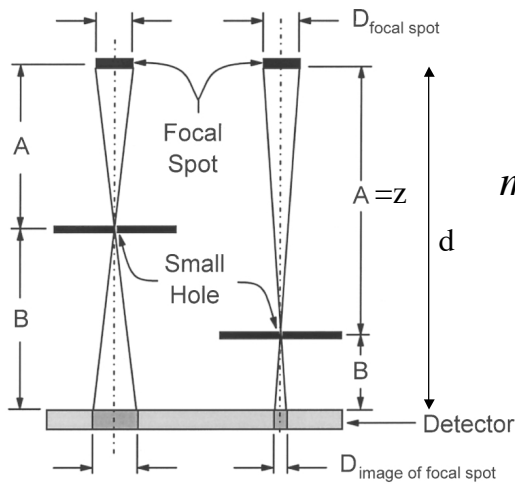

$$m(z) = -\frac{d-z}{z} = -\frac{B}{A}$$

$$= 1 - M(z)$$

Bushberg et al 2001

TT Liu, BE280A, UCSD Fall 2006

Image of a point object

$s(x,y)$



$$I_d(x,y) = \lim_{m \rightarrow 0} ks(x/m, y/m)$$

$$= \delta(x,y)$$

$s(x,y)$



$m=1$



$$I_d(x,y) = ks(x,y)$$

In general,

$$I_d(x,y) = ks(x/m, y/m)$$

TT Liu, BE280A, UCSD Fall 2006

Image of arbitrary object

$s(x,y)$



$t(x,y)$



$$\lim_{m \rightarrow 0} I_d(x,y) = t(x,y)$$

$s(x,y)$



$t(x,y)$



$m=1$

$$I_d(x,y) = ???$$

$$I_d(x,y) = ks(x/m, y/m) ** t(x/M, y/M)$$

TT Liu, BE280A, UCSD Fall 2006

Note: we are ignoring obliquity, etc.

Film-screen blurring

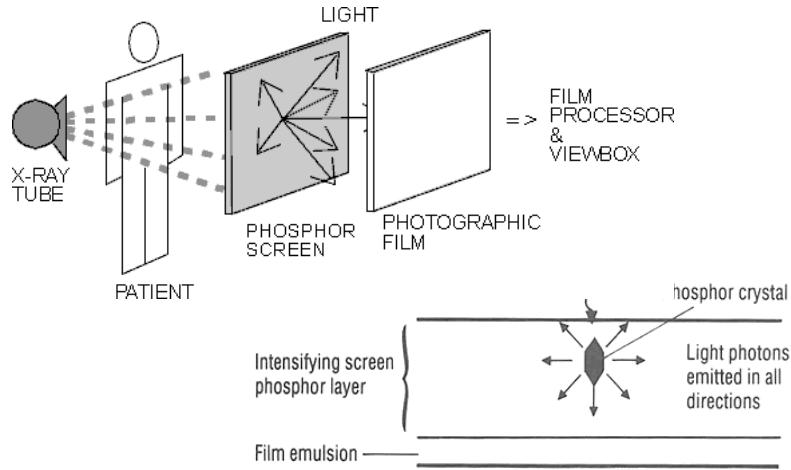

$$I_d(x, y) = ks(x/m, y/m) ** t(x/M, y/M) ** h(x, y)$$

http://learntech.uwe.ac.uk/radiography/RScience/imaging_principles_d/diagimage11.htm
<http://www.sunnybrook.utoronto.ca:8080/~selenium/xray.html#Film>

TT Liu, BE280A, UCSD Fall 2006

Convolution

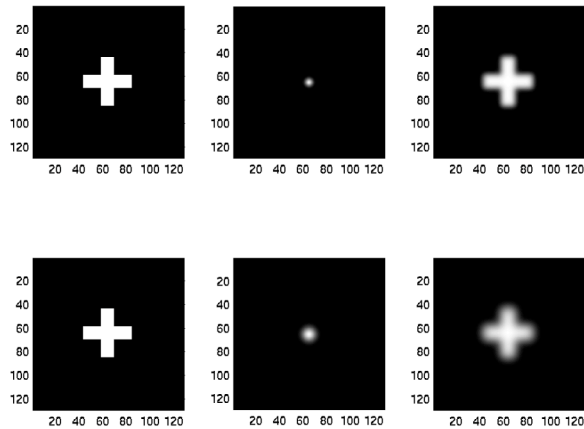

TT Liu, BE280A, UCSD Fall 2006

Signals and Images

Discrete-time/space signal/image: continuous valued function with a discrete time/space index, denoted as $s[n]$ for 1D, $s[m,n]$ for 2D, etc.

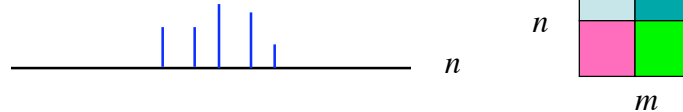

Continuous-time/space signal/image: continuous valued function with a continuous time/space index, denoted as $s(t)$ or $s(x)$ for 1D, $s(x,y)$ for 2D, etc.

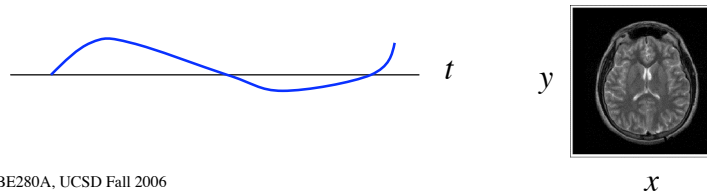

TT Liu, BE280A, UCSD Fall 2006

Kronecker Delta Function

$$\delta[n] = \begin{cases} 1 & \text{for } n = 0 \\ 0 & \text{otherwise} \end{cases}$$

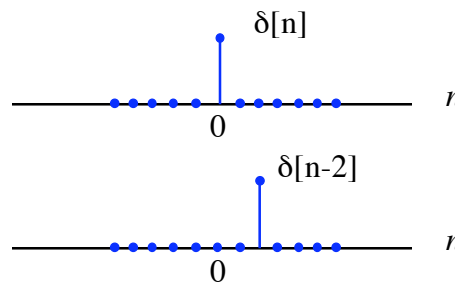

TT Liu, BE280A, UCSD Fall 2006

Kronecker Delta Function

$$\delta[m,n] = \begin{cases} 1 & \text{for } m = 0, n = 0 \\ 0 & \text{otherwise} \end{cases}$$

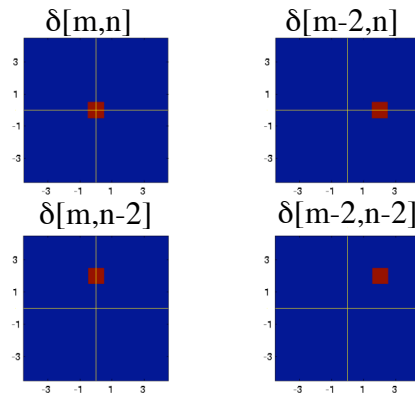

TT Liu, BE280A, UCSD Fall 2006

Discrete Signal Expansion

$$g[n] = \sum_{k=-\infty}^{\infty} g[k]\delta[n-k]$$

$$g[m,n] = \sum_{k=-\infty}^{\infty} \sum_{l=-\infty}^{\infty} g[k,l]\delta[m-k,n-l]$$

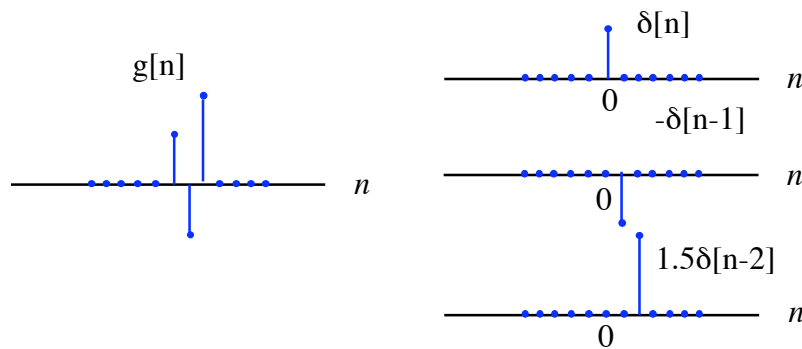

TT Liu, BE280A, UCSD Fall 2006

2D Signal

$$\begin{array}{|c|c|} \hline a & b \\ \hline c & d \\ \hline \end{array} = \begin{array}{|c|c|} \hline a & 0 \\ \hline 0 & 0 \\ \hline \end{array} + \begin{array}{|c|c|} \hline 0 & b \\ \hline 0 & 0 \\ \hline \end{array} + \begin{array}{|c|c|} \hline 0 & 0 \\ \hline c & 0 \\ \hline \end{array} + \begin{array}{|c|c|} \hline 0 & 0 \\ \hline 0 & d \\ \hline \end{array}$$

TT Liu, BE280A, UCSD Fall 2006

Image Decomposition

$$\begin{array}{|c|c|} \hline c & d \\ \hline a & b \\ \hline \end{array} = \begin{array}{|c|c|} \hline c & 1 & 0 \\ \hline 0 & 0 \\ \hline \end{array} + \begin{array}{|c|c|} \hline d & 0 & 1 \\ \hline 0 & 0 \\ \hline \end{array} + \begin{array}{|c|c|} \hline a & 0 & 0 \\ \hline 1 & 0 \\ \hline \end{array} + \begin{array}{|c|c|} \hline b & 0 & 0 \\ \hline 0 & 1 \\ \hline \end{array}$$

$$g[m,n] = a\delta[m,n] + b\delta[m,n-1] + c\delta[m-1,n] + d\delta[m-1,n-1]$$

$$= \sum_{k=0}^1 \sum_{l=0}^1 g[k,l]\delta[m-k,n-l]$$

TT Liu, BE280A, UCSD Fall 2006

Dirac Delta Function

Notation :

$\delta(x)$ - 1D Dirac Delta Function

$\delta(x,y)$ or ${}^2\delta(x,y)$ - 2D Dirac Delta Function

$\delta(x,y,z)$ or ${}^3\delta(x,y,z)$ - 3D Dirac Delta Function

$\delta(\vec{r})$ - N Dimensional Dirac Delta Function

TT Liu, BE280A, UCSD Fall 2006

1D Dirac Delta Function

$\delta(x) = 0$ when $x \neq 0$ and $\int_{-\infty}^{\infty} \delta(x) dx = 1$

Can interpret the integral as a limit of the integral of an ordinary function that is shrinking in width and growing in height, while maintaining a constant area. For example, we can use a shrinking rectangle function

such that $\int_{-\infty}^{\infty} \delta(x) dx = \lim_{\tau \rightarrow 0} \int_{-\infty}^{\infty} \tau^{-1} \Pi(x/\tau) dx$.

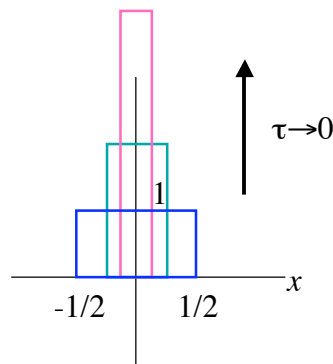

TT Liu, BE280A, UCSD Fall 2006

2D Dirac Delta Function

$$\delta(x,y) = 0 \text{ when } x^2 + y^2 \neq 0 \text{ and } \int_{-\infty}^{\infty} \int_{-\infty}^{\infty} \delta(x,y) dx dy = 1$$

where we can consider the limit of the integral of an ordinary 2D function that is shrinking in width but increasing in height while maintaining constant area.

$$\int_{-\infty}^{\infty} \int_{-\infty}^{\infty} \delta(x,y) dx dy = \lim_{\tau \rightarrow 0} \int_{-\infty}^{\infty} \int_{-\infty}^{\infty} \tau^{-2} \Pi(x/\tau, y/\tau) dx dy.$$

Useful fact : $\delta(x,y) = \delta(x)\delta(y)$

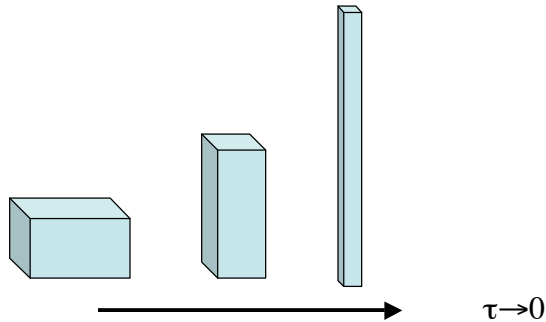

TT Liu, BE280A, UCSD Fall 2006

Generalized Functions

Dirac delta functions are not ordinary functions that are defined by their value at each point. Instead, they are generalized functions that are defined by what they do underneath an integral.

The most important property of the Dirac delta is the sifting property

$\int_{-\infty}^{\infty} \delta(x - x_0) g(x) dx = g(x_0)$ where $g(x)$ is a smooth function. This sifting property can be understood by considering the limiting case

$$\lim_{\tau \rightarrow 0} \int_{-\infty}^{\infty} \tau^{-1} \Pi(x/\tau) g(x) dx = g(x_0)$$

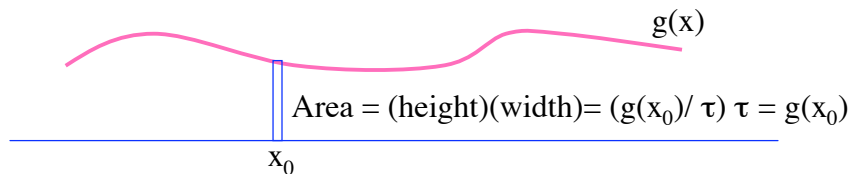

TT Liu, BE280A, UCSD Fall 2006

Representation of 1D Function

From the sifting property, we can write a 1D function as

$g(x) = \int_{-\infty}^{\infty} g(\xi)\delta(x - \xi)d\xi$. To gain intuition, consider the approximation

$$g(x) \approx \sum_{n=-\infty}^{\infty} g(n\Delta x) \frac{1}{\Delta x} \Pi\left(\frac{x - n\Delta x}{\Delta x}\right)\Delta x.$$

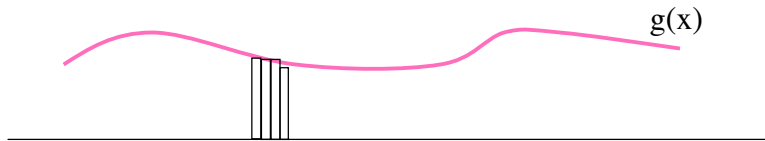

TT Liu, BE280A, UCSD Fall 2006

Representation of 2D Function

Similarly, we can write a 2D function as

$$g(x, y) = \int_{-\infty}^{\infty} \int_{-\infty}^{\infty} g(\xi, \eta)\delta(x - \xi, y - \eta)d\xi d\eta.$$

To gain intuition, consider the approximation

$$g(x, y) \approx \sum_{m=-\infty}^{\infty} \sum_{n=-\infty}^{\infty} g(n\Delta x, m\Delta y) \frac{1}{\Delta x} \Pi\left(\frac{x - n\Delta x}{\Delta x}\right) \frac{1}{\Delta y} \Pi\left(\frac{y - m\Delta y}{\Delta y}\right)\Delta x\Delta y.$$

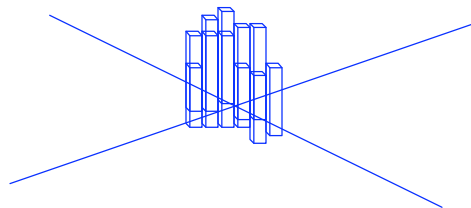

TT Liu, BE280A, UCSD Fall 2006

Impulse Response

Intuition: the impulse response is the response of a system to an input of infinitesimal width and unit area.

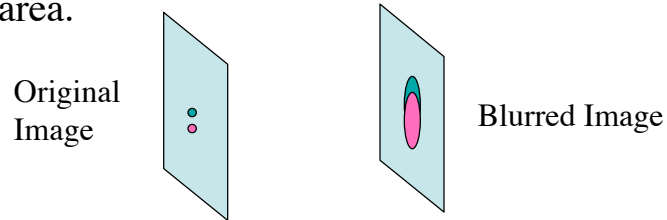

Since any input can be thought of as the weighted sum of impulses, a linear system is characterized by its impulse response(s).

TT Liu, BE280A, UCSD Fall 2006

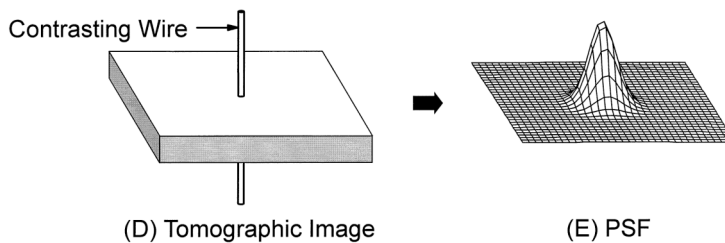
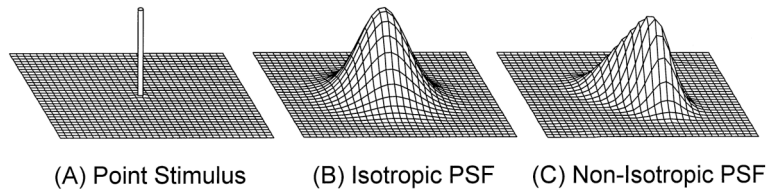

Bushberg et al 2001

TT Liu, BE280A, UCSD Fall 2006

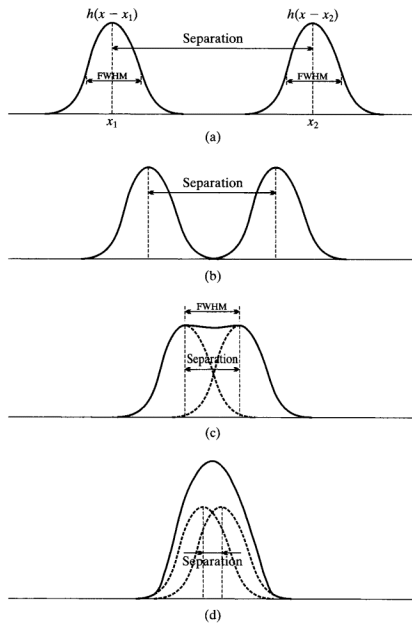

Full Width Half Maximum (FWHM) is a measure of resolution.

Figure 3.6
An example of the effect of system resolution on the ability to differentiate two points. The FWHM equals the minimum distance that the two points must be separated in order to be distinguishable.

Prince and Link 2005

Impulse Response

The impulse response characterizes the response of a system over all space to a Dirac delta impulse function at a certain location.

$$h(x_2; \xi) = L[\delta(x_1 - \xi)] \quad \text{1D Impulse Response}$$

$$h(x_2, y_2; \xi, \eta) = L[\delta(x_1 - \xi, y_1 - \eta)] \quad \text{2D Impulse Response}$$

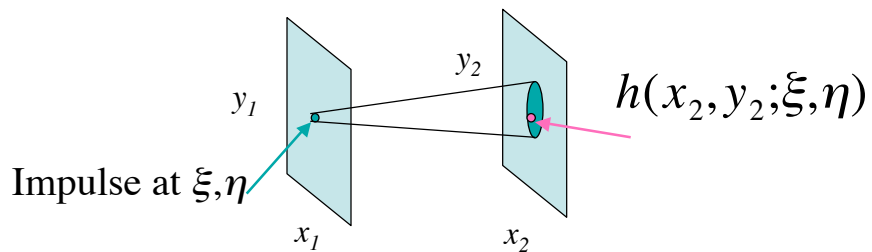

TT Liu, BE280A, UCSD Fall 2006

Pinhole Magnification Example

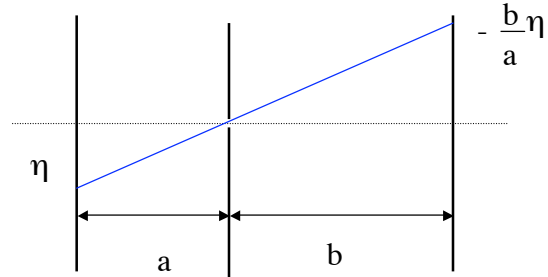

In this example, an impulse at (ξ, η) will yield an impulse at $(m\xi, m\eta)$ where $m = -b/a$.

Thus, $h(x_2, y_2; \xi, \eta) = L[\delta(x_1 - \xi, y_1 - \eta)] = \delta(x_2 - m\xi, y_2 - m\eta)$.

TT Liu, BE280A, UCSD Fall 2006

Linearity (Addition)

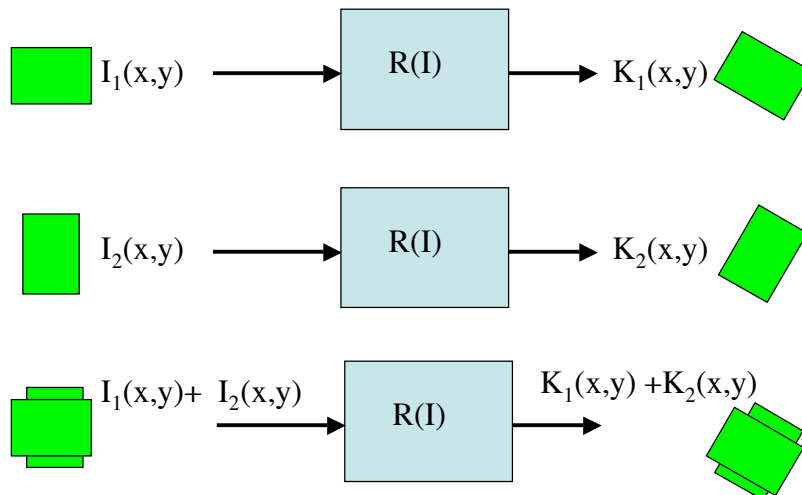

TT Liu, BE280A, UCSD Fall 2006

Linearity (Scaling)

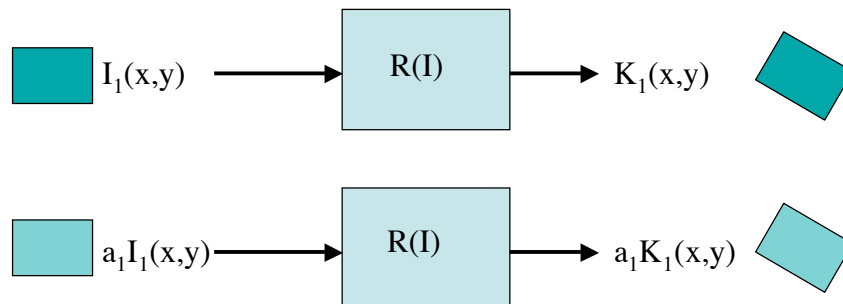

TT Liu, BE280A, UCSD Fall 2006

Linearity

A system R is linear if for two inputs $I_1(x,y)$ and $I_2(x,y)$ with outputs

$$R(I_1(x,y))=K_1(x,y) \text{ and } R(I_2(x,y))=K_2(x,y)$$

the response to the weighted sum of inputs is the weighted sum of outputs:

$$R(a_1 I_1(x,y) + a_2 I_2(x,y)) = a_1 K_1(x,y) + a_2 K_2(x,y)$$

TT Liu, BE280A, UCSD Fall 2006

Example

Are these linear systems?

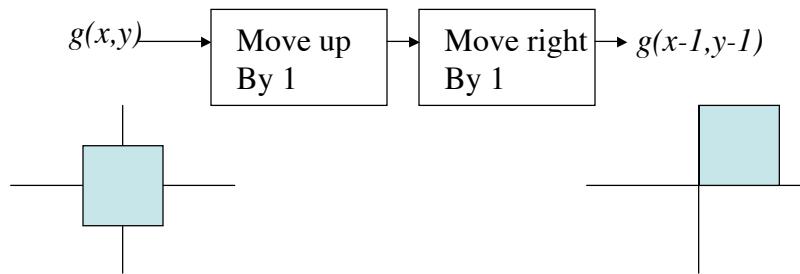
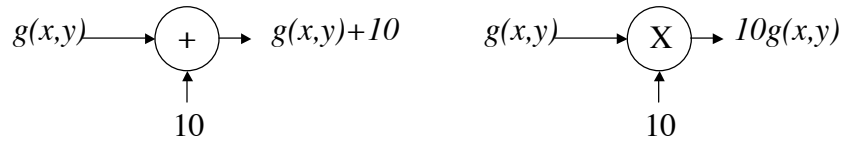

TT Liu, BE280A, UCSD Fall 2006

Superposition Integral

What is the response to an arbitrary function $g(x_1, y_1)$?

$$\text{Write } g(x_1, y_1) = \int_{-\infty}^{\infty} \int_{-\infty}^{\infty} g(\xi, \eta) \delta(x_1 - \xi, y_1 - \eta) d\xi d\eta.$$

The response is given by

$$\begin{aligned} I(x_2, y_2) &= L[g_1(x_1, y_1)] \\ &= L\left[\int_{-\infty}^{\infty} \int_{-\infty}^{\infty} g(\xi, \eta) \delta(x_1 - \xi, y_1 - \eta) d\xi d\eta\right] \\ &= \int_{-\infty}^{\infty} \int_{-\infty}^{\infty} g(\xi, \eta) L[\delta(x_1 - \xi, y_1 - \eta)] d\xi d\eta \\ &= \int_{-\infty}^{\infty} \int_{-\infty}^{\infty} g(\xi, \eta) h(x_2, y_2; \xi, \eta) d\xi d\eta \end{aligned}$$

TT Liu, BE280A, UCSD Fall 2006

Pinhole Magnification Example

$$\begin{aligned} I(x_2, y_2) &= \int_{-\infty}^{\infty} \int_{-\infty}^{\infty} g(\xi, \eta) h(x_2, y_2; \xi, \eta) d\xi d\eta \\ &= C \int_{-\infty}^{\infty} \int_{-\infty}^{\infty} g(\xi, \eta) \delta(x_2 - m\xi, y_2 - m\eta) d\xi d\eta \end{aligned}$$

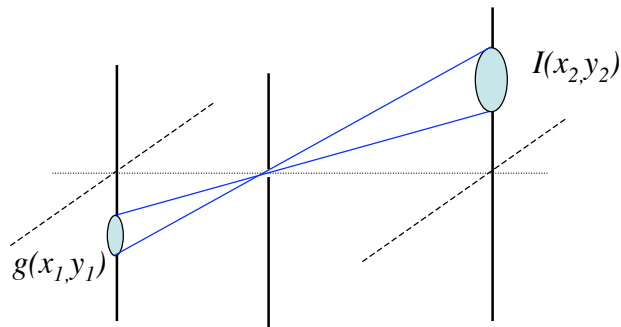

TT Liu, BE280A, UCSD Fall 2006

Space Invariance

If a system is space invariant, the impulse response depends only on the difference between the output coordinates and the position of the impulse and is given by $h(x_2, y_2; \xi, \eta) = h(x_2 - \xi, y_2 - \eta)$

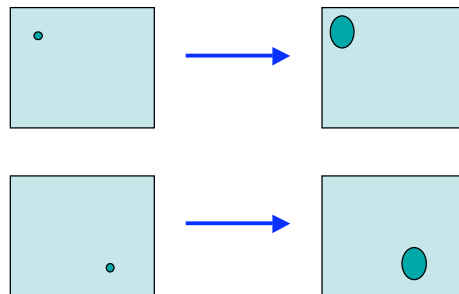

TT Liu, BE280A, UCSD Fall 2006

Pinhole Magnification Example

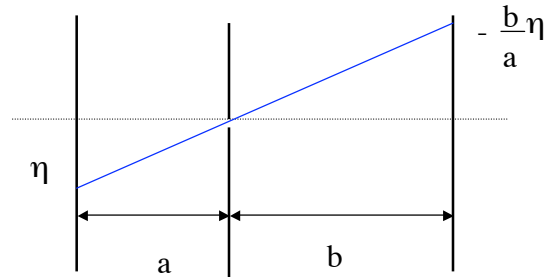

$$h(x_2, y_2; \xi, \eta) = C \delta(x_2 - m\xi, y_2 - m\eta) .$$

Is this system space invariant?

TT Liu, BE280A, UCSD Fall 2006

Pinhole Magnification Example

____, the pinhole system ____ space invariant.

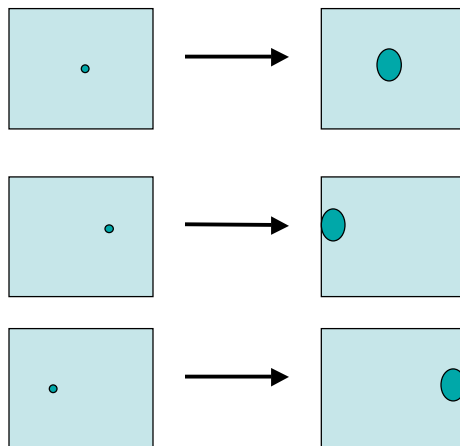

TT Liu, BE280A, UCSD Fall 2006

2D Convolution

For a space invariant linear system, the superposition integral becomes a convolution integral.

$$\begin{aligned} I(x_2, y_2) &= \int_{-\infty}^{\infty} \int_{-\infty}^{\infty} g(\xi, \eta) h(x_2, y_2; \xi, \eta) d\xi d\eta \\ &= \int_{-\infty}^{\infty} \int_{-\infty}^{\infty} g(\xi, \eta) h(x_2 - \xi, y_2 - \eta) d\xi d\eta \\ &= g(x_2, y_2) ** h(x_2, y_2) \end{aligned}$$

where ** denotes 2D convolution. This will sometimes be abbreviated as *, e.g. $I(x_2, y_2) = g(x_2, y_2) * h(x_2, y_2)$.

TT Liu, BE280A, UCSD Fall 2006

1D Convolution

For completeness, here is the 1D version.

$$\begin{aligned} I(x) &= \int_{-\infty}^{\infty} g(\xi) h(x; \xi) d\xi \\ &= \int_{-\infty}^{\infty} g(\xi) h(x - \xi) d\xi \\ &= g(x) * h(x) \end{aligned}$$

Useful fact:

$$\begin{aligned} g(x) * \delta(x - \Delta) &= \int_{-\infty}^{\infty} g(\xi) \delta(x - \Delta - \xi) d\xi \\ &= g(x - \Delta) \end{aligned}$$

TT Liu, BE280A, UCSD Fall 2006

Rectangle Function

$$\Pi(x) = \begin{cases} 0 & |x| > 1/2 \\ 1 & |x| \leq 1/2 \end{cases}$$

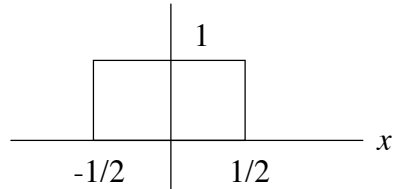

Also called $\text{rect}(x)$

$$\Pi(x,y) = \Pi(x)\Pi(y)$$

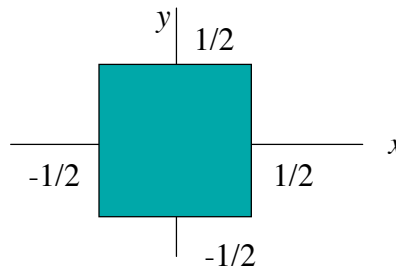

TT Liu, BE280A, UCSD Fall 2006

2D Convolution Example

$$g(x) = \delta(x+1/2, y) + \delta(x, y)$$

$$h(x) = \text{rect}(x, y)$$

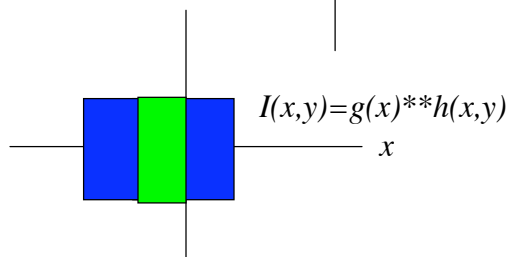
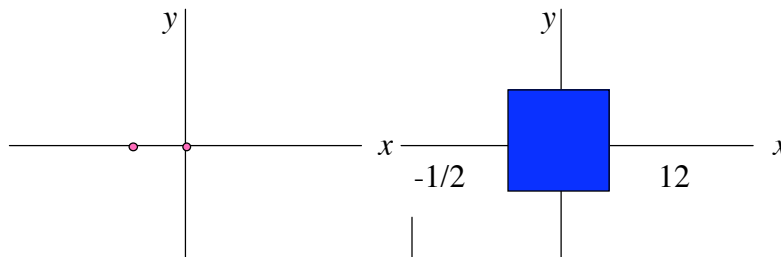

TT Liu, BE280A, UCSD Fall 2006

2D Convolution Example

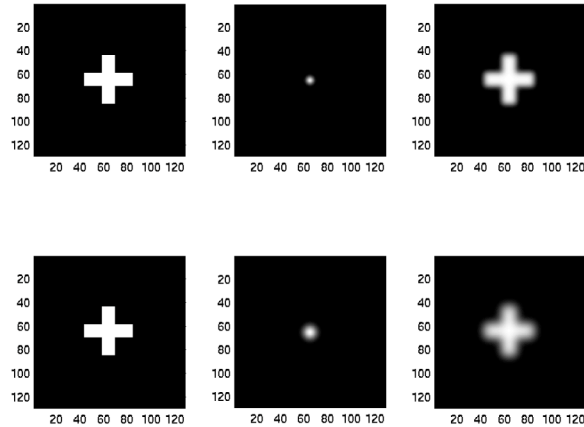

TT Liu, BE280A, UCSD Fall 2006

Pinhole Magnification Example

$$\begin{aligned}
 I(x_2, y_2) &= \int_{-\infty}^{\infty} \int_{-\infty}^{\infty} s(\xi, \eta) h(x_2, y_2; \xi, \eta) d\xi d\eta \\
 &= \int_{-\infty}^{\infty} \int_{-\infty}^{\infty} s(\xi, \eta) \delta(x_2 - m\xi, y_2 - m\eta) d\xi d\eta
 \end{aligned}$$

after substituting $\xi' = m\xi$ and $\eta' = m\eta$, we obtain

$$\begin{aligned}
 &= \frac{1}{m^2} \int_{-\infty}^{\infty} \int_{-\infty}^{\infty} s(\xi'/m, \eta'/m) \delta(x_2 - \xi', y_2 - \eta') d\xi' d\eta' \\
 &= \frac{1}{m^2} s(x_2/m, y_2/m) * \delta(x_2, y_2) \\
 &= \frac{1}{m^2} s(x_2/m, y_2/m)
 \end{aligned}$$

TT Liu, BE280A, UCSD Fall 2006

Image of a point object

$s(x,y)$



$$I_d(x,y) = \lim_{m \rightarrow 0} ks(x/m, y/m)$$

$$= \delta(x,y)$$

$s(x,y)$



$m=1$



$$I_d(x,y) = s(x,y)$$

In general,

$$I_d(x,y) = \frac{1}{m^2} s(x/m, y/m)$$

TT Liu, BE280A, UCSD Fall 2006

Pinhole Magnification Example

$$I(x_2, y_2) = \int_{-\infty}^{\infty} \int_{-\infty}^{\infty} s(\xi, \eta) h(x_2, y_2; \xi, \eta) d\xi d\eta$$

$$= \int_{-\infty}^{\infty} \int_{-\infty}^{\infty} s(\xi, \eta) t\left(\frac{x_2 - m\xi}{M}, \frac{y_2 - m\eta}{M}\right) d\xi d\eta$$

after substituting $\xi' = m\xi$ and $\eta' = m\eta$, we obtain

$$= \frac{1}{m^2} \int_{-\infty}^{\infty} \int_{-\infty}^{\infty} s(\xi'/m, \eta'/m) t\left(\frac{x_2 - \xi'}{M}, \frac{y_2 - \eta'}{M}\right) d\xi' d\eta'$$

$$= \frac{1}{m^2} s(x_2/m, y_2/m) ** t(x_2/M, y_2/M)$$

TT Liu, BE280A, UCSD Fall 2006

Image of arbitrary object

$s(x,y)$



$t(x,y)$



$$\lim_{m \rightarrow 0} I_d(x,y) = t(x,y)$$

$s(x,y)$



$t(x,y)$



$m=1$

$$I_d(x,y) = ???$$

$$I_d(x,y) = \frac{1}{m^2} s(x/m, y/m) ** t(x/M, y/M)$$

TT Liu, BE280A, UCSD Fall 2006

Note: we are ignoring obliquity, etc.

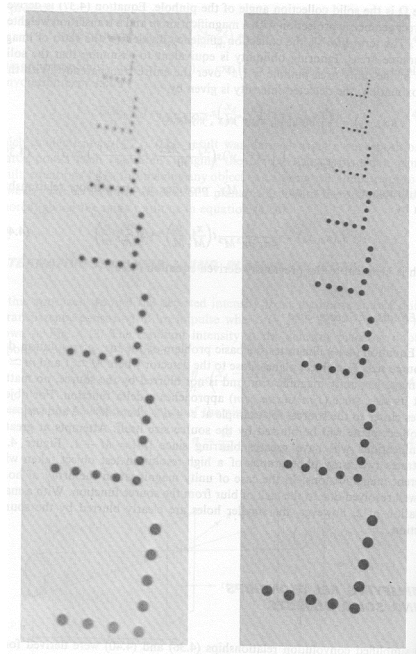

TT Liu, BE280A, UCSD Fall 2006

Macovski 1983

Summary

1. The response to a linear system can be characterized by a spatially varying impulse response and the application of the superposition integral.
2. A shift invariant linear system can be characterized by its impulse response and the application of a convolution integral.
3. Dirac delta functions are generalized functions.