

Bioengineering 280A  
Principles of Biomedical Imaging

Fall Quarter 2007  
CT Lecture 1

TT Liu, BE280A, UCSD Fall 2007

Computed Tomography

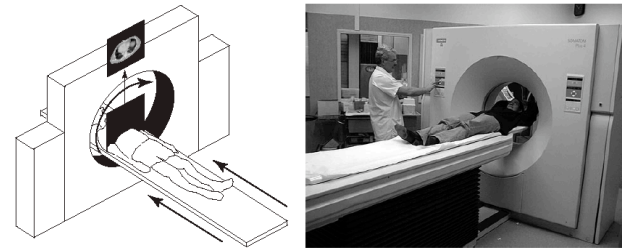

TT Liu, BE280A, UCSD Fall 2007

Suetens 2002

Computed Tomography

Parallel  
Beam

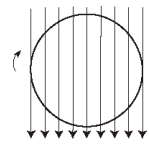

(a)

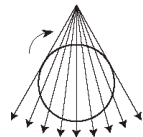

(b)

Fan  
Beam

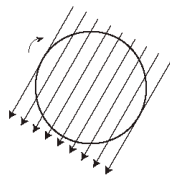

(c)

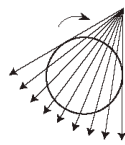

(d)

TT Liu, BE280A, UCSD Fall 2007

Suetens 2002

Scanner Generations

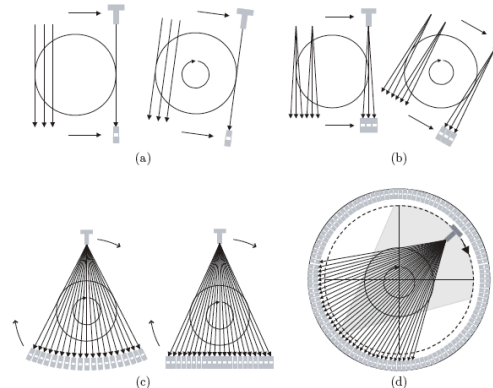
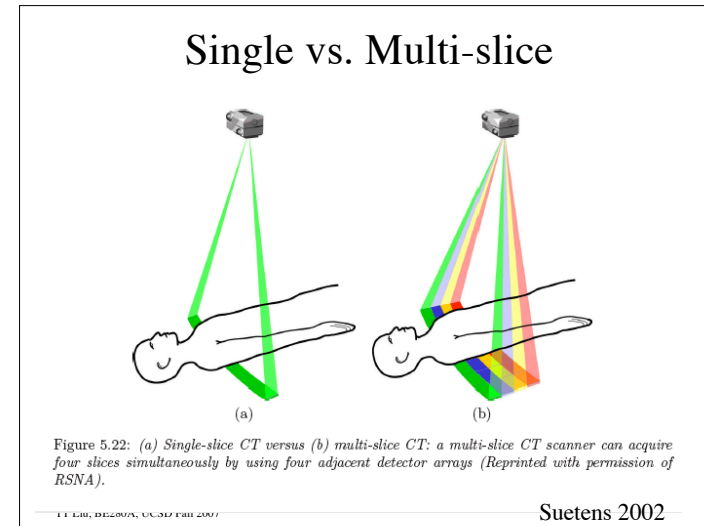
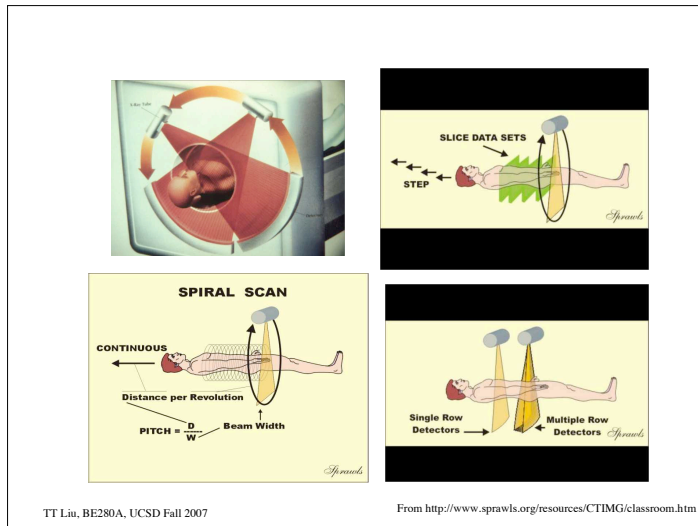

Figure 5.19: Subsequent scanner generations: (a) first generation, (b) second generation, (c) third generation and (d) fourth generation CT scanner.  
TT Liu, BE280A, UCSD Fall 2007

Suetens 2002



### Scanner Generations

TABLE 6.1  
Comparison of CT Generations

Generation	Source	Source Collimation	Detector	Detector Collimation	Source-Detector Movement	Advantages	Disadvantages
1G	Single x-ray tube	Pencil beam	Single	None	Move linearly and rotate in unison	Scattered energy is undetected	Slow
2G	Single x-ray tube	Fan beam, not enough to cover FOV	Multiple	Collimated to source direction	Move linearly and rotate in unison	Faster than 1G	Lower efficiency and larger noise because of the collimation in detectors
3G	Single x-ray tube	Fan beam, enough to cover FOV	Many	Collimated to source direction	Rotate in synchrony	Faster than 2G, continuous rotation using a slip ring.	More expensive than 2G, low efficiency
4G	Single x-ray tube	Fan beam covers FOV	Stationary ring of detectors	Cannot collimate detectors	Detectors are fixed, source rotates	Higher efficiency than 3G	High scattering since detectors are not collimated
5G (EBCT)	Many tungsten anodes in single large tube	Fan beam	Stationary ring of detectors	Cannot collimate detectors	No moving parts	Extremely fast, capable of stop-action imaging of beating heart	High cost, difficult to calibrate
6G (Spiral CT)	3G/4G	3G/4G	3G/4G	3G/4G	3G/4G plus linear patient table motion	Fast 3D images	A bit more expensive
7G (Multislice CT)	Single x-ray tube	Cone beam	Multiple arrays of detectors	Collimated to source direction	3G/4G/6G motion	Fast 3D images	Expensive

Prince and Links 2005

TT Liu, BE280A, UCSD Fall 2007

### 1G vs. 2G scanner

Example 6.1 from Prince and Links.

Compare 1G vs. 2G scanner whose source - detector apparatus can move linearly at speed of 1 m/sec; FOV 0.5m; 360 projections over 180 degrees; 0.5 s for apparatus to rotate one angular increment, regardless of angle.

Question : Scan time for 1 G scanner? Scan time for 2G scanner with 9 detectors space 0.5 degrees apart?

Answer :

1G scanner :  $0.5m/(1m/s) = 0.5s$  per projection.  
 $360 * 0.5 = 180s$  scan time  
 $360 * 0.5 = 180s$  for rotation of apparatus.  
 Total time = 360 s or 6 minutes.

2G scanner : Required angular resolution is  $180/360 = 0.5$  degrees -- agrees with spacing.  
 $360/9 = 40$  rotations required.  
 $40 * 0.5 = 20s$  for scanning  
 $40 * 0.5 = 20s$  for rotations.  
 Total time = 40s.

TT Liu, BE280A, UCSD Fall 2007

## 3G, 6G, and 7G scanners

3G scanner: Typical scanner acquires 1000 projections with fanbeam angle of 30 to 60 degrees; 500 to 700 detectors; 1 to 20 seconds.

6G: Spiral/Helical CT

60 cm torso scan: 30s.

24 cm lung scan: 12s

15 cm angio: 30s

7G: Multislice CT

64 or more parallel 1D projections.

TT Liu, BE280A, UCSD Fall 2007

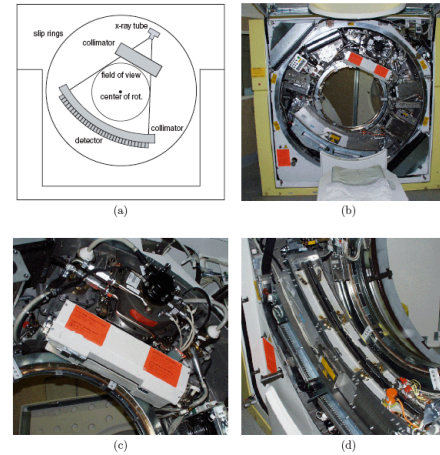

Figure 5.20: (a-b) The basic internal geometry of a third generation spiral CT scanner. (c) X-ray tube with adjustable collimating split. (d) Detector array with post-patient collimator.

TT Liu, BE280A, UCSD Fall 2007

Suetens 2002

## Detectors

Figure 6.7

(a) Solid-state detectors, (b) xenon gas detectors, and (c) multiple (solid-state) detector array.

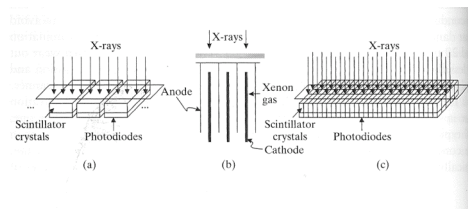

TT Liu, BE280A, UCSD Fall 2007

Prince and Links 2005

## CT Line Integral

$$I_d = \int_0^{E_{\max}} S_0(E) E \exp\left(-\int_0^d \mu(s; E) ds\right) dE$$

Monoenergetic Approximation

$$I_d = I_0 \exp\left(-\int_0^d \mu(s; \bar{E}) ds\right)$$

$$g_d = -\log\left(\frac{I_d}{I_0}\right)$$

$$= \int_0^d \mu(s; \bar{E}) ds$$

TT Liu, BE280A, UCSD Fall 2007

## CT Number

$$CT\_number = \frac{\mu - \mu_{water}}{\mu_{water}} \times 1000$$

Measured in Hounsfield Units (HU)

Air: -1000 HU

Soft Tissue: -100 to 60 HU

Cortical Bones: 250 to 1000 HU

Metal and Contrast Agents: > 2000 HU

TT Liu, BE280A, UCSD Fall 2007

## CT Display

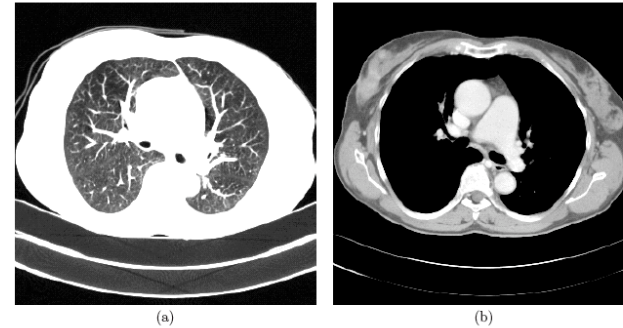

Figure 5.4: CT-image of the chest with different window/level settings:(a) for the lungs (window 1500 and level -500) and (b) for the soft tissues (window 350 and level 50).

TT Liu, BE280A, UCSD Fall 2007

Suetens 2002

## Direct Inverse Approach

$\mu_1$	$\mu_2$
$\mu_3$	$\mu_4$

$$\begin{array}{l}
 p_1 \\
 p_2 \\
 p_3 \\
 p_4
 \end{array}
 =
 \begin{array}{l}
 \mu_1 + \mu_2 \\
 \mu_3 + \mu_4 \\
 \mu_1 + \mu_3 \\
 \mu_2 + \mu_4
 \end{array}
 \begin{array}{l}
 \begin{bmatrix} p_1 \\ p_2 \\ p_3 \\ p_4 \end{bmatrix} = \begin{bmatrix} 1 & 1 & 0 & 0 \\ 0 & 0 & 1 & 1 \\ 1 & 0 & 1 & 0 \\ 0 & 1 & 0 & 1 \end{bmatrix} \begin{bmatrix} \mu_1 \\ \mu_2 \\ \mu_3 \\ \mu_4 \end{bmatrix} \\
 \mu_1 \\
 \mu_2 \\
 \mu_3 \\
 \mu_4
 \end{array}$$

4 equations, 4 unknowns.

Are these the correct equations to use?

TT Liu, BE280A, UCSD Fall 2007

## Direct Inverse Approach

$\mu_1$	$\mu_2$
$\mu_3$	$\mu_4$

$$\begin{array}{l}
 p_1 \\
 p_2 \\
 p_3 \\
 p_4
 \end{array}
 =
 \begin{array}{l}
 \mu_1 + \mu_2 \\
 \mu_3 + \mu_4 \\
 \mu_1 + \mu_3 \\
 \mu_2 + \mu_4
 \end{array}
 \begin{array}{l}
 \begin{bmatrix} p_1 \\ p_2 \\ p_3 \\ p_4 \end{bmatrix} = \begin{bmatrix} 1 & 1 & 0 & 0 \\ 0 & 0 & 1 & 1 \\ 1 & 0 & 1 & 0 \\ 0 & 1 & 0 & 1 \end{bmatrix} \begin{bmatrix} \mu_1 \\ \mu_2 \\ \mu_3 \\ \mu_4 \end{bmatrix} \\
 \mu_1 \\
 \mu_2 \\
 \mu_3 \\
 \mu_4
 \end{array}$$

4 equations, 4 unknowns.

Are these the correct equations to use?

TT Liu, BE280A, UCSD Fall 2007



## Projections

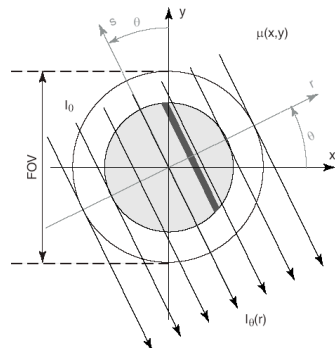

$$\begin{bmatrix} r \\ s \end{bmatrix} = \begin{bmatrix} \cos \theta & \sin \theta \\ -\sin \theta & \cos \theta \end{bmatrix} \begin{bmatrix} x \\ y \end{bmatrix}$$

$$\begin{bmatrix} x \\ y \end{bmatrix} = \begin{bmatrix} \cos \theta & -\sin \theta \\ \sin \theta & \cos \theta \end{bmatrix} \begin{bmatrix} r \\ s \end{bmatrix}$$

TT Liu, BE280A, UCSD Fall 2007

Suetens 2002

## Projections

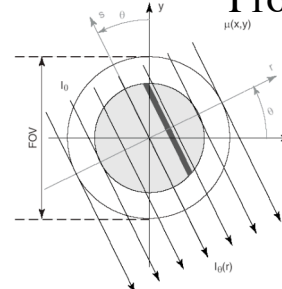

$$\begin{aligned} I(r, \theta) &= I_0 \exp\left(-\int_{L_r, \theta} \mu(x, y) ds\right) \\ &= I_0 \exp\left(-\int_{L_r, \theta} \mu(r \cos \theta - s \sin \theta, r \sin \theta + s \cos \theta) ds\right) \end{aligned}$$

TT Liu, BE280A, UCSD Fall 2007

Suetens 2002

## Projections

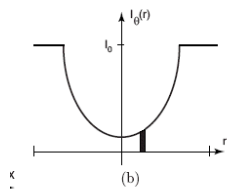

$$\begin{aligned} I(r, \theta) &= I_0 \exp\left(-\int_{L_r, \theta} \mu(r \cos \theta - s \sin \theta, r \sin \theta + s \cos \theta) ds\right) \\ p(r, \theta) &= -\ln \frac{I_0(r)}{I_0} \\ &= \int_{L_r, \theta} \mu(r \cos \theta - s \sin \theta, r \sin \theta + s \cos \theta) ds \end{aligned}$$

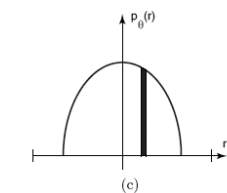

TT Liu, BE280A, UCSD Fall 2007

Suetens 2002

## Radon Transform

$$\begin{aligned} g(r, \theta) &= \int_{-\infty}^{\infty} \mu(x(s), y(s)) ds \\ &= \int_{-\infty}^{\infty} \mu(r \cos \theta - s \sin \theta, r \sin \theta + s \cos \theta) ds \\ &= \int_{-\infty}^{\infty} \int_{-\infty}^{\infty} \mu(x, y) \delta(x \cos \theta + y \sin \theta - r) dx dy \end{aligned}$$

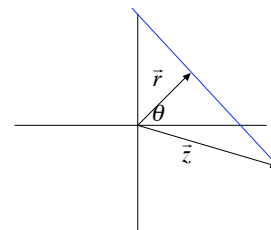

$$\begin{aligned} \vec{z} \cdot \frac{\vec{r}}{r} &= r \\ (x\hat{x} + y\hat{y}) \cdot (\cos \theta \hat{x} + \sin \theta \hat{y}) &= r \\ x \cos \theta + y \sin \theta &= r \end{aligned}$$

TT Liu, BE280A, UCSD Fall 2007

## Example

$$f(x,y) = \begin{cases} 1 & x^2 + y^2 \leq 1 \\ 0 & \text{otherwise} \end{cases}$$

$$\begin{aligned} g(l,\theta=0) &= \int_{-\infty}^{\infty} f(l,y) dy \\ &= \int_{-\sqrt{1-l^2}}^{\sqrt{1-l^2}} dy \\ &= \begin{cases} 2\sqrt{1-l^2} & |l| \leq 1 \\ 0 & \text{otherwise} \end{cases} \end{aligned}$$

TT Liu, BE280A, UCSD Fall 2007

## Sinogram

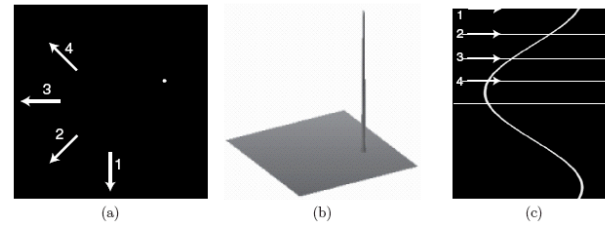

TT Liu, BE280A, UCSD Fall 2007

Suetens 2002

## y Backprojection

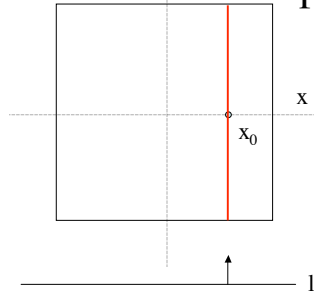

$$\begin{aligned} b(x_0, y) &= p(l, \theta=0) \Delta\theta \\ &= p(x_0, 0) \Delta\theta \end{aligned}$$

$$\begin{aligned} b_{\theta}(x, y) &= g(x \cos \theta + y \sin \theta, \theta) \Delta\theta \\ b(x, y) &= B\{g(l, \theta)\} \\ &= \int_0^{\pi} g(x \cos \theta + y \sin \theta, \theta) d\theta \end{aligned}$$

TT Liu, BE280A, UCSD Fall 2007

Suetens 2002

## Backprojection

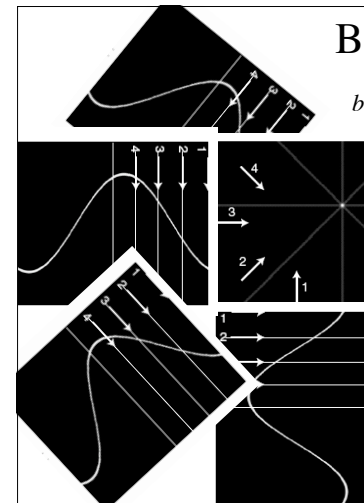

$$\begin{aligned} b(x, y) &= B\{p(l, \theta)\} \\ &= \int_0^{\pi} p(x \cos \theta + y \sin \theta, \theta) d\theta \end{aligned}$$

TT Liu, BE280A, UCSD Fall 2007

Suetens 2002

## Backprojection

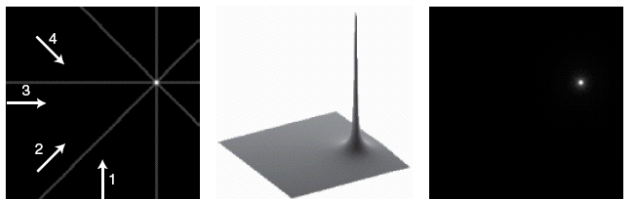

$$b(x, y) = B\{p(l, \theta)\} = \int_0^\pi p(x \cos \theta + y \sin \theta, \theta) d\theta$$

TT Liu, BE280A, UCSD Fall 2007

Suetens 2002

## Example

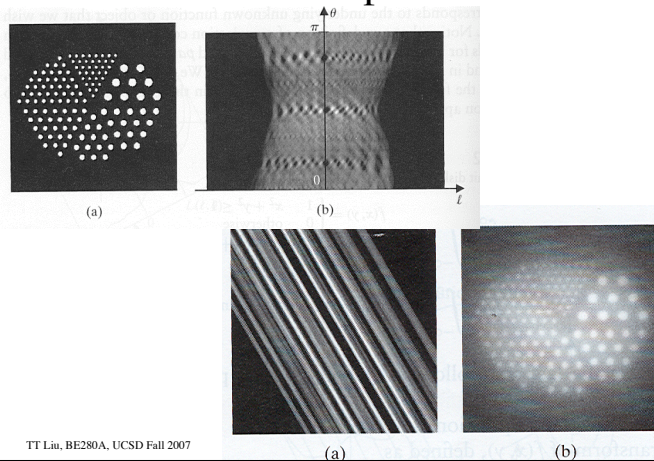

TT Liu, BE280A, UCSD Fall 2007